

Data Sheet

Customer :

Product : Aluminum Nitride Thin Film Precision Chip Resistor – ARN Series

Size: 1206/2512

Issued Date: 08-JUL-20

Edition : REV.A1



VIKING TECH CORPORATION
光韻科技股份有限公司

No.70, Guangfu N. Rad.,
Hsin Chu Industrial Park,
Hukou Hsiang, Hsin Chu Hsien,
303, Taiwan

TEL:886-3-5972931

FAX:886-3-5972935•886-3-5973494

E-mail:sales@viking.com.tw

VIKING TECH CORPORATION KAOHSIUNG BRANCH
光韻科技股份有限公司高雄分公司

No.248-3, Sin-Sheng Rd., Cian-Jhen Dist., Kaohsiung,
806, Taiwan

TEL:886-7-8217999

FAX:886-7-8228229

E-mail:sales@viking.com.tw

Viking Electronics (WUXI) CO., LTD.
光韻電子(無錫)有限公司

No.1A,(Xixia Road),Machinery & Industry Park,
National Hi-Tech Industrial Development Zone of
Wuxi, Wuxi, Jiangsu Province, China

Zip Code:214028

TEL:86-510-85203339

FAX:86-510-85203667•86-510-85203977

E-mail:wuxisales@tmtec.com.tw

Produced by (QC)	Checked (QC)	Approved by (QC)	Prepared by (Sales)	Accepted by (Customer)
08-JUL-20	08-JUL-20	08-JUL-20		
Chun	Ben Chang	Ben Chang		

Aluminum Nitride Thin Film Precision Chip Resistor (ARN Series)



■ Features

- High thermal conductivity aluminum nitride substrate
- Power rating up to 6.0W
- Resistance 50Ω ~ 30.1KΩ
- Resistor tolerance to ± 0.1%
- TCR to ± 25ppm/ ° C

■ Applications

- Power Supplies
- Power Switching
- Braking System

■ Typical Performance

- TCR. 25 ppm/°C
- TOL. 0.1 %

■ Construction

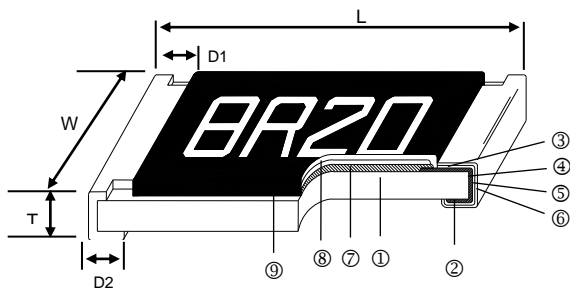

① Alumina Nitride Substrate	④ Edge Electrode	⑦ Resistor Layer
② Bottom Electrode	⑤ Barrier Layer	⑧ Overcoat
③ Top Electrode	⑥ External Electrode	⑨ Marking

■ Dimensions

Unit: mm

Type	Size (Inch)	L	W	T	D1	D2	Weight (g) (1000pcs)
ARN06	1206	3.05±0.20	1.55±0.20	0.43±0.15	0.50±0.15	1.20±0.20	10.98
ARN12	2512	6.30±0.20	3.10±0.20	0.43±0.15	0.70±0.25	1.60±0.25	42.32

■ Part Numbering

ARN	06	C	T	C	S	1000	N
Product Type	Dimensions (LxW)	Resistance Tolerance	Packaging Code	TCR (PPM/°C)	Power Rating	Resistance	Marking Code
	06: 1206 12: 2512	B: ±0.1% C: ±0.25% D: ±0.5% F: ±1%	T: Taping Reel B: Bulk	C: ±25 D: ±50	S : 2W I : 6W	1000: 100Ω 5000: 500Ω 1002: 10KΩ	:Standard Marking N: No Marking

Derating Curve

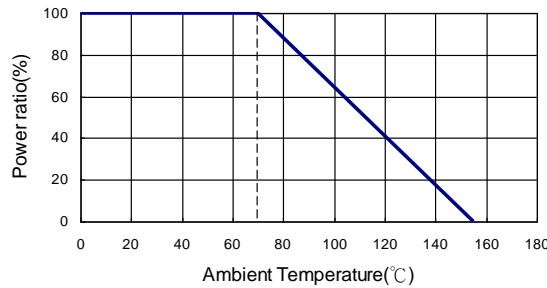

Standard Electrical Specifications

Type	Item	Power Rating at 70°C	Operating Temp. Range	Max Operating Voltage	Max Overload Voltage	Resistance Range				TCR (PPM/°C)
						±0.1%	±0.25%	±0.5%	±1%	
ARN06 (1206)		2W ⁽¹⁾	-55°C ~ +150°C	100V	200V	50Ω~30.1KΩ				±25 ±50
ARN06 (2512)		6W ⁽¹⁾	-55°C ~ +150°C	100V	200V	100Ω~30.1KΩ				±25 ±50

⁽¹⁾ Dependant on component mounting by user.

Operating Voltage= $\sqrt{P \cdot R}$ or Max. operating voltage listed above, whichever is lower.

■ Viking is capable of manufacturing the optional spec based on customer's requirement.

Environmental Characteristics

Item	Requirement	Test Method
Temperature Coefficient of Resistance (T.C.R.)	As Spec.	MIL-STD-202 Method 304 +25/-55/+25/+125/+25°C
Short Time Overload ⁽²⁾	$\Delta R \pm 0.5 \%$	Actual power handling capability is limited by the end user mounting process. As with any high power chip resistor the ability to remove the heat is critical to the overall performance of the device
Insulation Resistance	>9999MΩ	MIL-STD-202 Method 302 Apply 100V _{DC} for 1 minute
Endurance	$\Delta R \pm 1 \%$	MIL-STD-202 Method 108A 70±2°C, RCWV for 1000 hrs with 1.5 hrs "ON" and 0.5 hrs "OFF"
Damp Heat with Load	$\Delta R \pm 0.4 \%$	MIL-STD-202 Method 103B 40±2°C, 90~95% R.H. RCWV for 1000 hrs with 1.5 hrs "ON" and 0.5 hrs "OFF"
Solderability	95% min. coverage	MIL-STD-202 Method 208H 245±5°C for 3 seconds
Resistance to Soldering Heat	$\Delta R \pm 0.2 \%$	MIL-STD-202 Method 210E 260±5°C for 10 seconds
Low Temperature Operation	$\Delta R \pm 0.2 \%$	JIS-C-5201-1 4.36 1 hour, -65°C, followed by 45 minutes of RCWV
High Temperature Exposure	$\Delta R \pm 0.2 \%$	MIL-STD-202 Method 108 At + 155°C for 1000hrs
Thermal Shock	$\Delta R \pm 0.2 \%$	MIL-STD-202F Method 107G -55°C ~150°C, 100 cycles

RCWV(Rated continuous working voltage)= $\sqrt{P \cdot R}$ or Max. Operating voltage whichever is lower

■ Reference Standards: MIL-STD-202, JIS-C 5201

■ Storage Temperature: 15~28°C; Humidity < 80%RH

■ Chip Temp Vs. APPLIED POWER

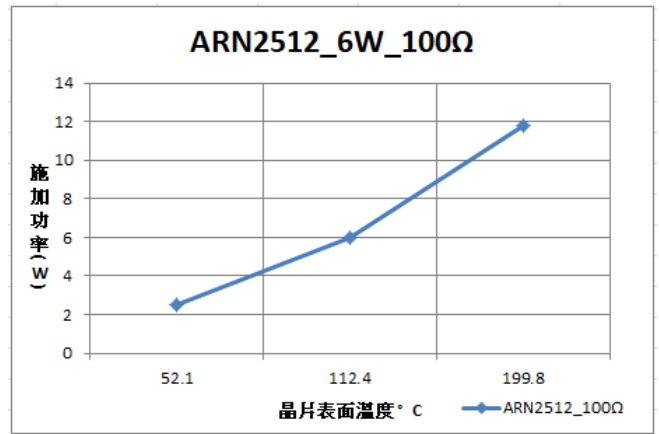
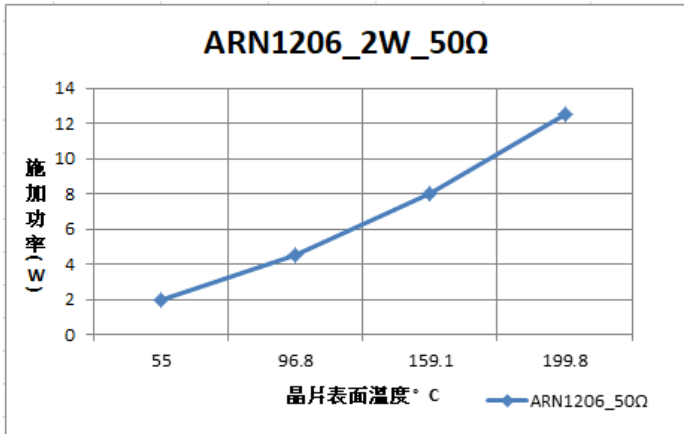

(2) Chip surface temperature measured using FLIR ETS-320 thermal imaging system with an approximate test card surface temperature

■ Soldering Condition

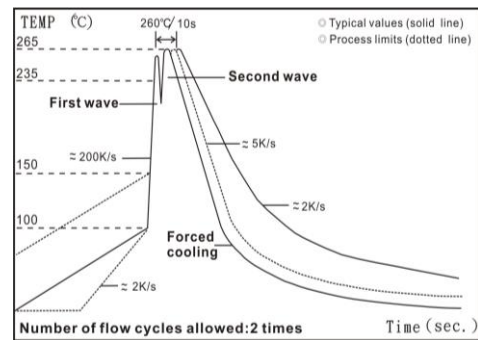
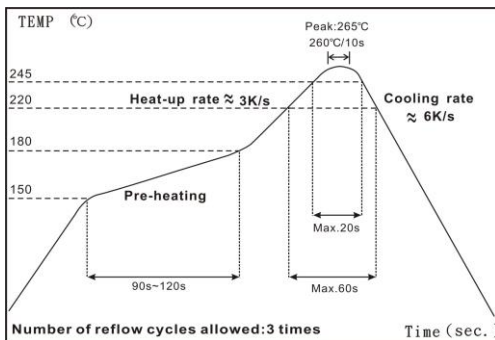

IR Reflow Soldering

Wave Soldering (Flow Soldering)

- (1) Time of IR reflow soldering at maximum temperature point $260^{\circ}C$: 10s
- (2) Time of wave soldering at maximum temperature point $260^{\circ}C$: 10s
- (3) Time of soldering iron at maximum temperature point $410^{\circ}C$: 5s

■ Marking

1206~2512 4digit marking

Example

Resistance	500Ω	2.2KΩ	10KΩ	12.5KΩ
marking	5000	2201	1002	1252

■ Packaging

Packing Quantity & Reel Specifications

Unit :mm

Type	ØA	ØB	ØC	W	T	Paper Tape (EA)	Emboss Plastic Tape (EA)
ARN06	178.0±1.0	60.0±1.0	13.5±0.7	9.5±1.0	11.5±1.0	5,000	-
ARN12	178.0±1.0	60.0±1.0	13.5±0.7	13.5±1.0	15.5±1.0		4,000

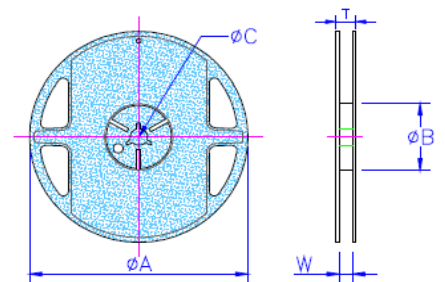

Paper Tape Specifications

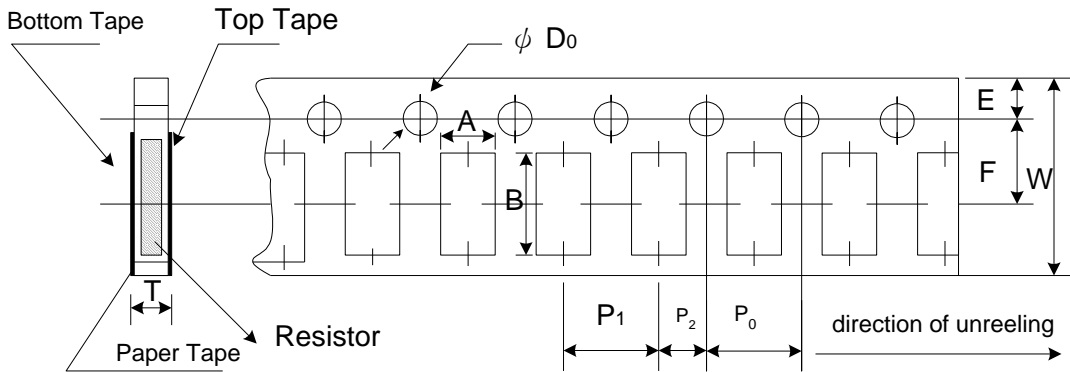

Unit: mm

Type	A	B	W	E	F	P ₀	P ₁	P ₂	ΦD ₀	T
ARN06	2.00±0.05	3.55±0.05	8.00±0.10	1.75±0.05	3.5±0.05	4.00±0.10	4.00±0.10	2.00±0.05	1.55±0.05	0.75±0.05

Emboss Plastic Tape Specifications

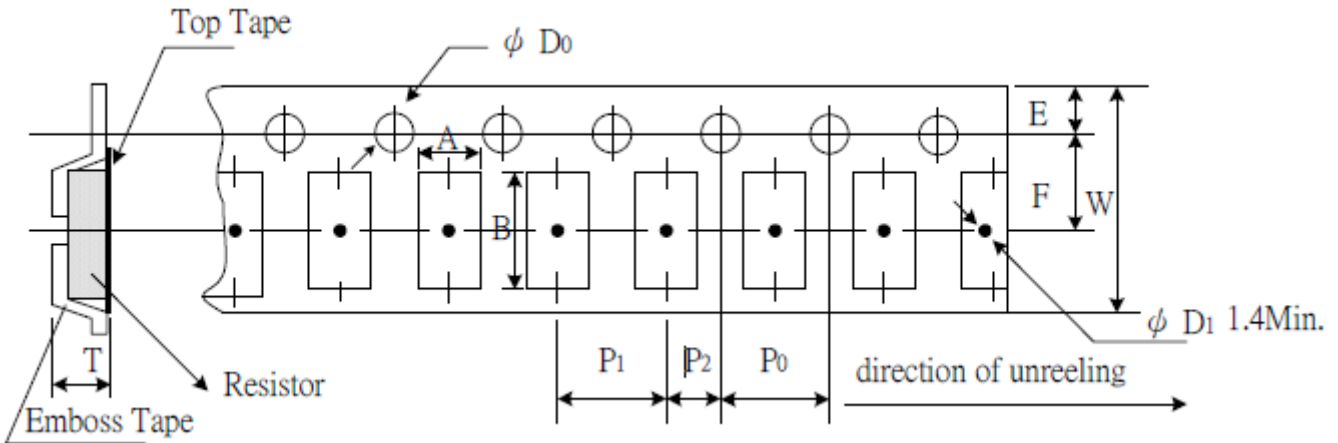

Type	A	B	W	E	F	P ₀	P ₁	P ₂	ΦD ₀	T
ARN12	3.40±0.10	6.65±0.10	12.0±0.10	1.75±0.10	5.5±0.05	4.00±0.10	4.00±0.10	2.00±0.05	1.50±0.10	1.00±0.20

- Peel force of top cover tape
- The peel speed shall be about 300mm/min±5%
- The peel force of top cover tape shall be between 8gf to 60gf

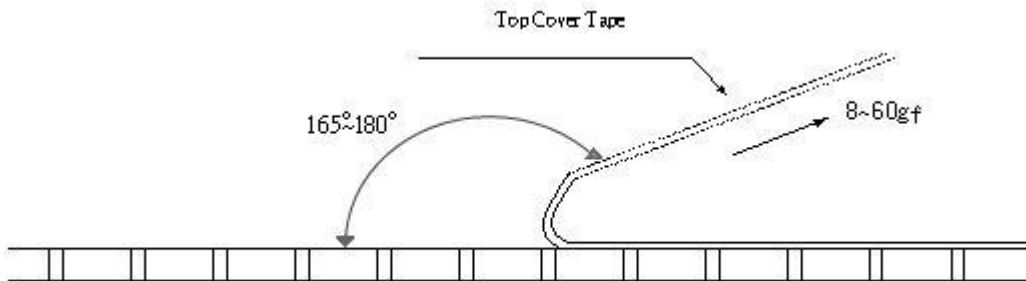

Recommend Land Pattern

Unit: mm

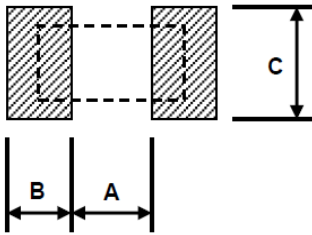

Type	A	B	C
ARN06	0.60	1.90	1.80±0.1
ARN12	2.77	2.31	3.20±0.2